

HF SChEMe: A Skywave Channel Error Model

Eric E. Johnson
New Mexico State University
Las Cruces, NM
ejohnson@nmsu.edu

Abstract

Simulation has been extensively employed to evaluate concepts included in the current generation of Automatic Link Establishment (ALE) High-Frequency (HF) radio systems. As development of HF automation proceeds from link-layer technology to network- and higher-layer technology, it is no longer necessary to devote great amounts of computer time to detailed simulation of the physical medium. Instead, the error behavior of the medium should be abstracted so that simulation resources may be concentrated on the phenomena of interest at these higher protocol layers.

In this paper, a model of channel error behavior is derived that accurately captures the operation of the ALE modem operating over Gaussian noise and skywave channels. When this model is employed in place of detailed simulation of the modem and channel, an overall simulation speedup of two orders of magnitude results.

Introduction

The current simulator suite for Automatic Link Establishment (ALE) High-Frequency (HF) radios (described in [1,2]) has been shown to accurately predict the impact on linking performance of a number of variations in the ALE protocols. However, this simulator requires significant computational resources: when executed on an IBM RS/6000 model 340 workstation (SPECmark 58), each simulated linking attempt requires approximately 1.27 s of CPU time. For link-level simulations this performance may be acceptable: linking performance is the metric of interest, and the simulation of 100 to 1000 linking attempts at perhaps 30 channel conditions requires only a few hours of CPU time on such a workstation.

However, when we are interested in evaluating the performance of networking algorithms and protocols, we will want to simulate several days of operations, which may include hundreds of thousands of link-level transmissions. The prospect of waiting several days for the results of simulating each alternative network protocol design prompted a search for a technique that speeds up the link-level simulation.

By profiling the execution time of the various functions composing the simulator, it was found that just over 94% of the

running time is spent in the HF channel simulator, and another 4% is spent in the modem FSK demodulator, with slightly under 1% of the simulation time spent in the Data Link Layer functions (see Figure 1). If an abstract model of the HF channel and ALE modem could be developed to replace the HF Channel Simulator and ALE Modem Simulator, the time to simulate each link-level transmission could be reduced by up to two orders of magnitude. The goal of the research reported here is the development of such a model.

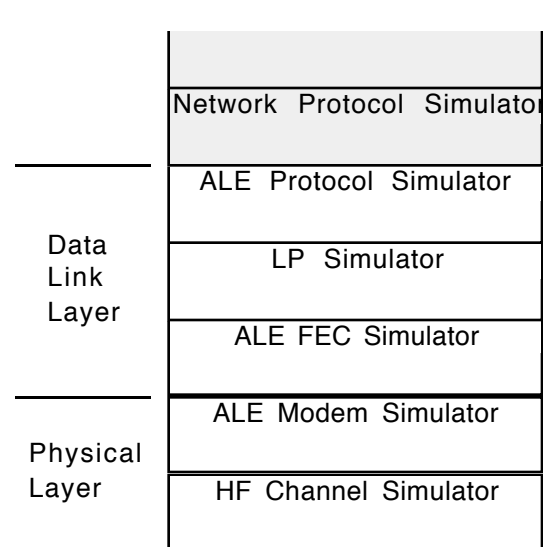

Figure 1. Simulator Stack

The requirements for the simulator module to be based upon this model are as follows:

- Plug-compatibility with the remaining modules of the ALE simulator. The new module must accept the symbol stream produced by the transmit FEC Simulator and return a symbol stream to the receive FEC Simulator.
- The returned symbol stream must differ from the transmit symbol stream (i.e., contain errors) in the same manner as for the full simulator. That is, the arrival process for errors must be indistinguishable for the two channel/modem (Physical Layer) simulators, as viewed by the ALE Protocol Simulator.
- The new Physical Layer simulator should read the channel characteristics to be simulated from the same global variables as the current modules, so that no changes are required in the Data Link Layer modules when switching between the two Physical Layer simulators.

This work supported by the NTIA Institute for Telecommunications Sciences, Systems and Networks Division.

Background

The behavior of a channel is described by the manner in which it introduces errors into the symbols which are passed through it. This behavior is typically described in terms of the distribution of bit errors; however, we are concerned with the 8-ary FSK ALE modem, so it is more natural to work with 3-bit symbols and to discuss the distribution of bit errors within symbols separately from the occurrences of symbol errors.

Channel Characterization

The error behavior of the ALE modem working in both Gaussian noise and fading (skywave) channels was obtained by modifying the full ALE simulator shown in Figure 1 to log every symbol received in error during linking simulations. This approach ensured that the sequences of symbols presented to the channel during the measurement of channel performance were identical to those that would be encountered in practice.

The resulting log files were processed to extract the various channel characteristics used in this research. Each log entry listed the symbol sent, the symbol received, and the number of symbols sent since the immediately previous symbol error.

The first investigation using these logs was a determination of the distribution of bit errors within symbols received with errors. It was found that each of the 7 possible error patterns was equally likely, independent of the transmitted symbol.

The arrival process of *symbol* errors can be characterized in a variety of ways. The simplest is to plot the symbol error rate versus the channel (3 KHz) signal to noise ratio (SNR), as shown in Figure 2. However, this is insufficient to fully characterize the channels, as seen in the figure: the Good and Poor channels* produce essentially identical curves, despite having markedly different linking performance (Figure 3).

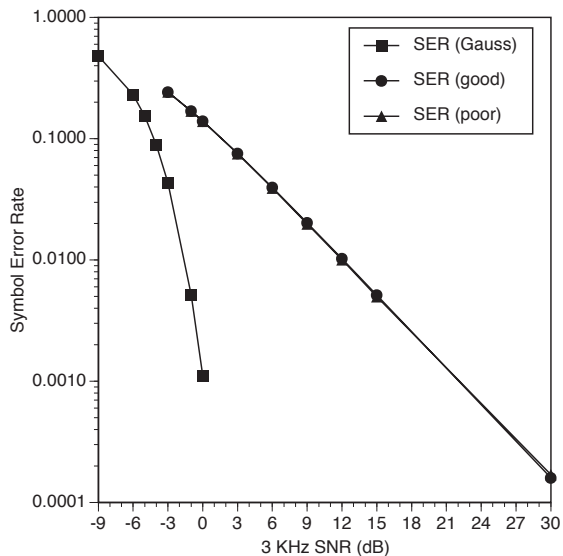

Figure 2. Channel Error Rate (full simulator)

* Both of these channels exhibit selective fading. The Good channel is characterized by 0.5 ms multipath delay and 0.1 Hz Doppler spread, while the Poor channel simulated has 2 ms multipath delay and 2 Hz Doppler spread (note that this differs from the CCIR Poor channel, which uses a 1 Hz Doppler spread).

Binary Symmetric Channel

The simplest model of a communication channel is one in which the probability of an error is independent of the history of errors on the channel. This memoryless model is usually called the Binary Symmetric Channel (BSC). The probability of a symbol error, p , is also termed the symbol error rate, SER. Because of its memoryless behavior, the probability of one or more errors in a consecutive block of N symbols, termed the block error rate or BLER(N), is given by

$$\text{BLER}(N) = 1 - (1-p)^N$$

The block error rates computed from the simulation logs for our three example channels are shown in Figure 4. The Additive White Gaussian Noise (AWGN) channel fits the BSC model well, but the fading channels exhibit significant burstiness.

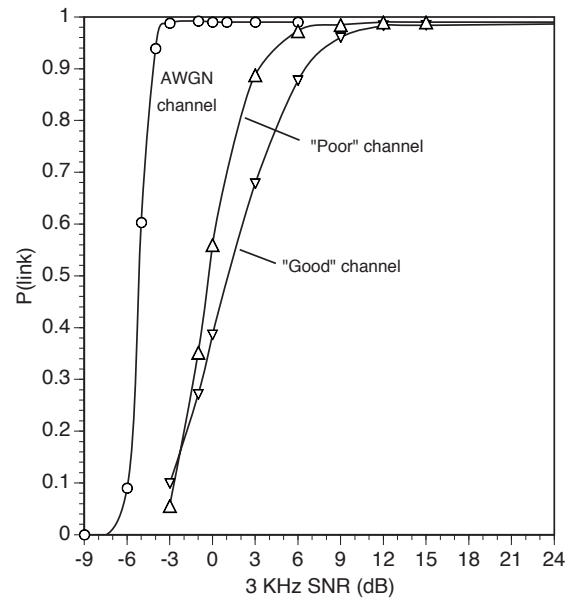

Figure 3. Linking Performance (full simulator)

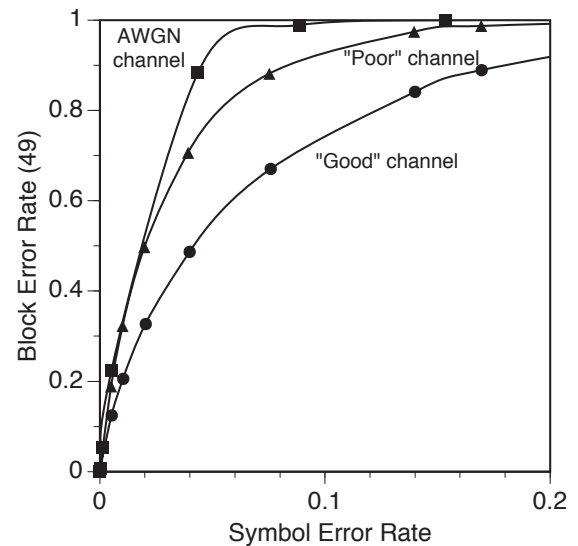

Figure 4. BLER(49) vs. SER

The error behavior of the BSC may be represented as a state diagram, as seen in Figure 5. In this Moore Finite State Machine (FSM), the single state variable determines whether or not to introduce an error for the current symbol: in the error state, an error is introduced, while in the non-error state, no error is introduced. The probability of making a state transition to the error state (from either state) is simply p , the probability of a symbol error.

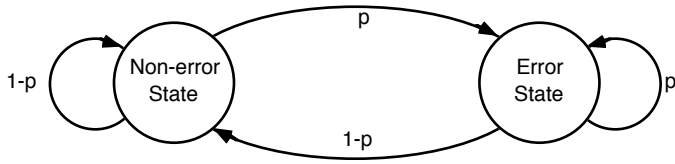

Figure 5. BSC State Diagram

Single-Error-State Models

The BSC model can be generalized to a multi-state Markov model with a single error state as described in [3]. The key feature of such a Single-Error-State (SES) model is that transitions are permitted only between the error state and one of the non-error states (Figure 6); no transitions are permitted among the non-error states. This has the effect of introducing N_S-1 different geometric distributions for error-free runs between adjacent error bursts.

A procedure is described in [3] by which pairs of SER and BLER measurements can be converted into the A_i and ρ_i parameters of an SES model. The number of non-error states resulting from this procedure will equal the number of pairs of measurements used.

For use in a simulator, this initial model must then be modified to generate precisely the SER desired. This is achieved by removing any states that lead to an SER lower than desired, and then adding one state with its A_i and ρ_i parameters calculated to bring the SER to exactly the desired value.

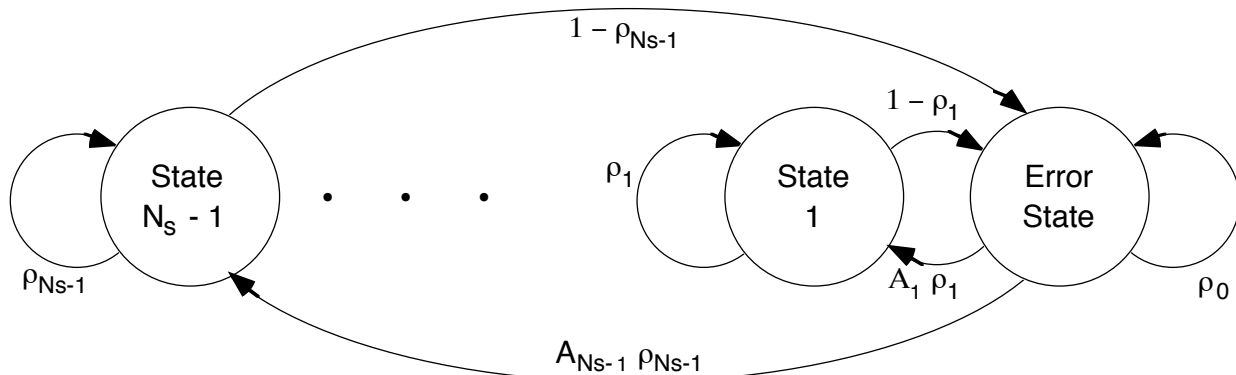

Figure 6. Single-Error-State Model State Diagram

Skywave Model

As noted previously, the BSC was found to accurately model the AWGN channel. In this section, the design of a model for the fading (skywave) channels is presented.

Fixed-State Markov Models

Because of the complications of handling varying numbers of states in the simulator as the SER to be produced changes, an initial attempt was made to produce a model with a fixed number of states, either one non-error state (resulting in a two-state Markov model) or two non-error states (producing a three-state Markov model). These fixed-state Markov models were ultimately unable to accurately represent the error burst characteristics of the HF skywave channel.

Single-Error-State Model

The approach finally selected for the HF SChEMe (Skywave Channel Error Model) is a version of the SES model, parameterized using four pairs of (SER, BLER) measurements. Corresponding measurements were collected from channel error logs of four fading channels, and are listed in Table 1. The SER values for the four channels did not differ significantly (see Figure 2), so the mean values of the four SER measurements are used for all fading channels.

By interpolating among the BLER values listed, estimates of BLER(49) can be obtained for any combination of channel conditions within the bounds of the measured channels. (Extrapolation beyond these bounds may be unreliable.)

Performance Evaluation

The performance of the simulator based upon this model can be gauged in two ways: its speedup relative to the full simulation, and the fidelity of its results to those obtained using the full simulator. Addressing speedup first, the time per simulated linking attempt for the full simulator is 1.27 s on an IBM RS/6000 model 340; using SChEMe in place of the channel and modem simulators, each linking attempt is simulated in 0.014 s. This represents a speedup ratio of 91. (Both measurements were averaged over 1000 linking attempts using a Poor channel with 0 dB SNR. Other channels produced similar results.)

Table 1. Channel Error Measurements

SNR (dB)	SER	BLER (49)			
-3	0.2432	0.9572	0.9010	0.9995	0.9978
-1	0.1694	0.8895	0.7784	0.9947	0.9875
0	0.1396	0.8415	0.7015	0.9880	0.9746
+3	0.0756	0.6707	0.4694	0.9251	0.8816
Multipath delay (ms)		0.5000	2.0000	0.5000	2.0000
Doppler Spread (Hz)		0.1000	0.1000	2.0000	2.0000

The fidelity of the SChEMe simulator is seen in Figures 7 through 9, which show simulated linking probabilities for the full simulator, the SChEMe simulator, and the two fixed-state Markov simulators. Clearly, the fidelity of the HF SChEMe is excellent for the Gaussian and Poor channels, and is also quite good for the Good channel.

Conclusion

The use of a single-error-state model of HF skywave channel performance in simulations of data-link-layer (and higher) protocols yields two orders of magnitude improvement in simulation speed, while introducing little error into performance statistics collected at levels of abstraction above the physical layer.

Future Work

A research project is planned at New Mexico State University (NMSU) to use the model described here in HF network simulations running on parallel computers. The combination of speedups from using SChEMe and executing the simulation in parallel should result in timely simulations of much more complicated systems than are presently possible.

In the future, we also plan to revise SChEMe to incorporate a wideband channel model in place of the current Watterson model, and to develop an equivalent model for PSK modems.

References

1. E.E. Johnson, R.S. Moore, and C.C. Weng, "An HF Channel and Modem Simulator Package," Technical Report NMSU-ECE-91-005, July 1991.
2. E.E. Johnson and R.S. Moore, "HF ALE Simulator," Technical Report NMSU-ECE-92-001, January 1992.
3. L.E. Vogler, "An Extended Single-Error-State Model for Bit Error Statistics," NTIA Report 86-195, July 1986.

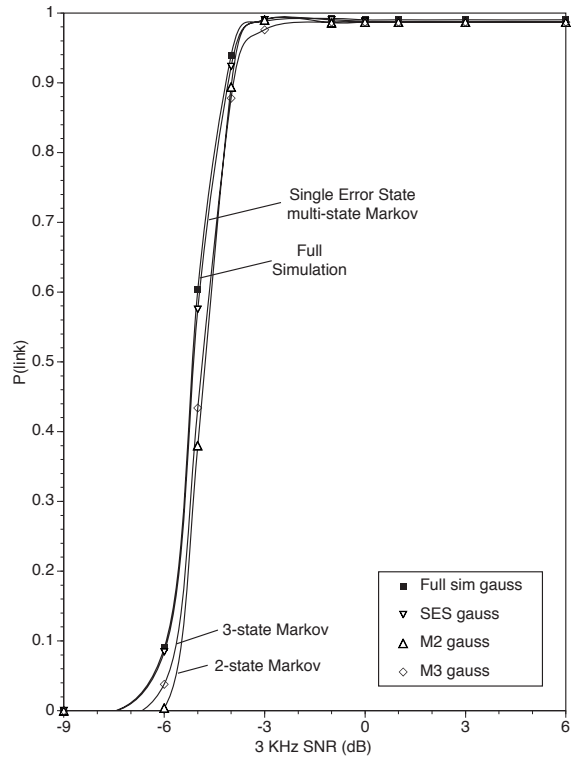

Figure 7. Gaussian (AWGN) Channel Comparison

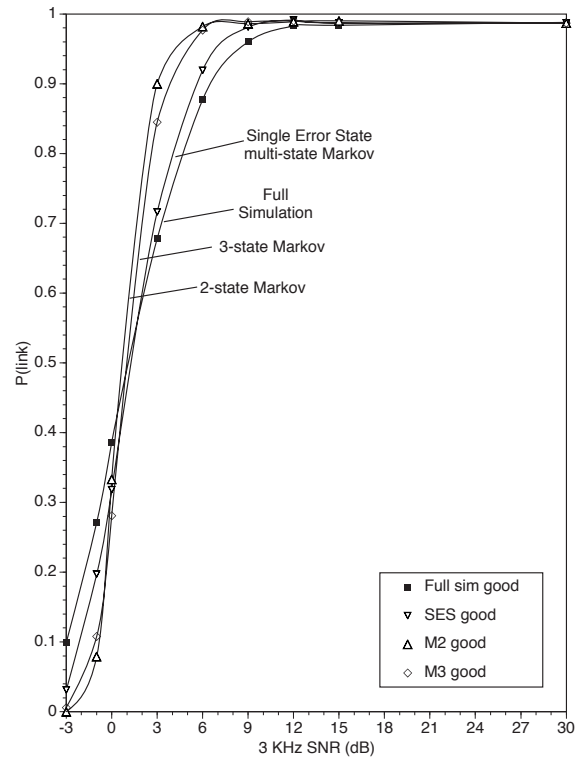

Figure 8. Good Channel Comparison (0.5 ms, 0.1 Hz)

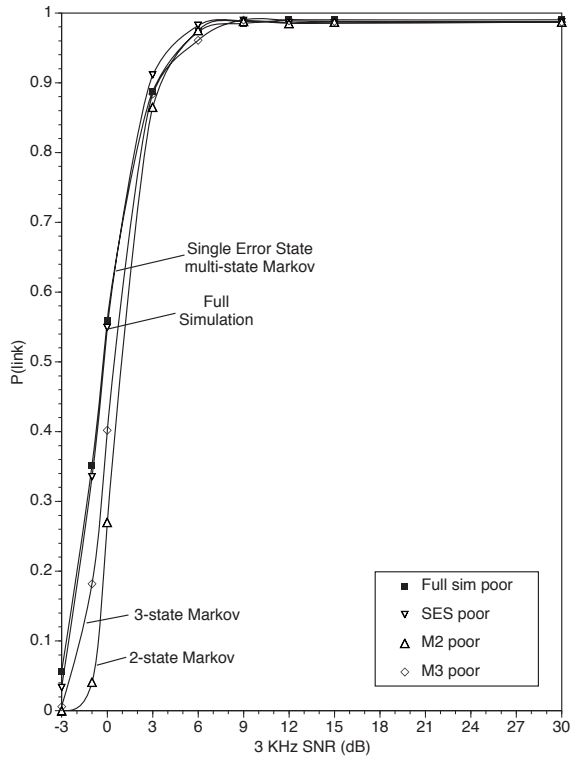

Figure 9. Poor Channel Comparison (2.0 ms, 2.0 Hz)